



M Series

Underwater Connectors



Presentation

The M Series connectors meet the highest standards of safety for deep immersion. It is currently used in many applications: from oil and gas industry service to renewable energy generation system and military submarines.

The M Series feature a large range of shell styles, layouts or insulator materials. No matter you need to convey signal information or high power we have the right product or we can make it.

Contents

Overview

Typical applications	6
Features & Benefits	7
Range overview	10

Standard Range

Product description	15
Technical features	17
Ordering information.....	19
Contacts	21
Contact layouts	22
Cable clamp accessories	25
Shell dimensions	28
Tools and wiring instructions	38

Range Extension

Double watertightness connectors	42
Oil filled connectors	42
Specific shells	43
Optical M connectors	43
Size 28M	44
High current/High voltage.....	44

Other Series

TP Series.....	48
U Series	48
8810 Series - Underwater mateable	49

MARINE SERIES

M Series

Overview

■ Typical applications	6
■ Features & Benefits	7
■ Range overview	8

Typical applications

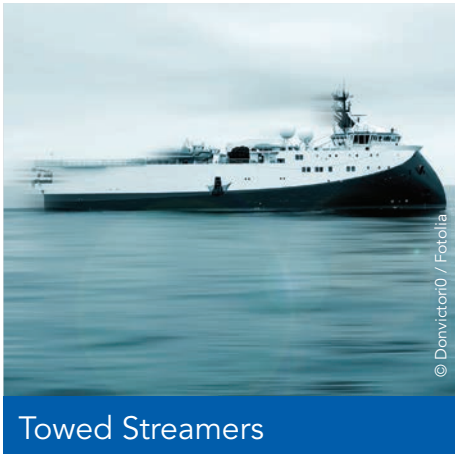
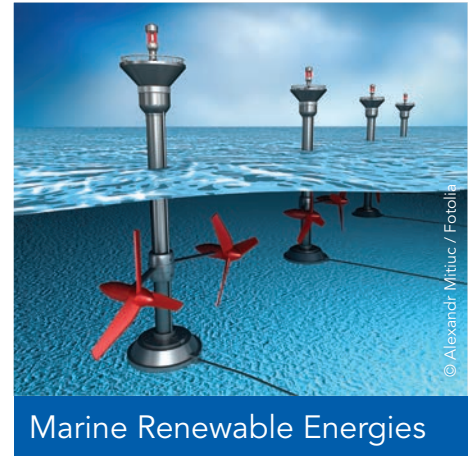

Features & Benefits

FIELD PROVEN

Extensively Used in Underwater Application

Oil and Gas services: Geophysics, inspection or instrumentation
ROVs and AUVs
Military marine: Submarines, torpedoes or vessels
Marine Renewable Energy: Tidal turbine, farm architecture...

ROBUST

Designed for Harsh Environment

Repairable connectors with removable inserts
No stress on O-rings by conical coupling interface
Extreme resistance to pull-out or transverse forces, vibrations and shocks
Double sealing security thanks to two O-rings in coupling interface

PERFOR- MANCES

High Performance Levels

Withstanding 500 cycles mating/unmating
Standard watertightness products tested at 200 bars
Up to 300 bars for the overmolded versions
Up to 1000 bars for the oil filled versions

LARGE OFFER

Standard and Special Products

Contacts: Signal, high speed (optical, triax...), high power
Wide range of body styles and sizes
Single, double watertightness or overmolded on cable termination

Features & Benefits

Sealed and reliable connectors

- ▶ O-ring for insert to shell sealing on both plug and receptacle
- ▶ Redundancy with 2 O-rings on plug taper seat for plug to receptacle sealing
- ▶ Conical coupling interface to reduce the stress on O-rings

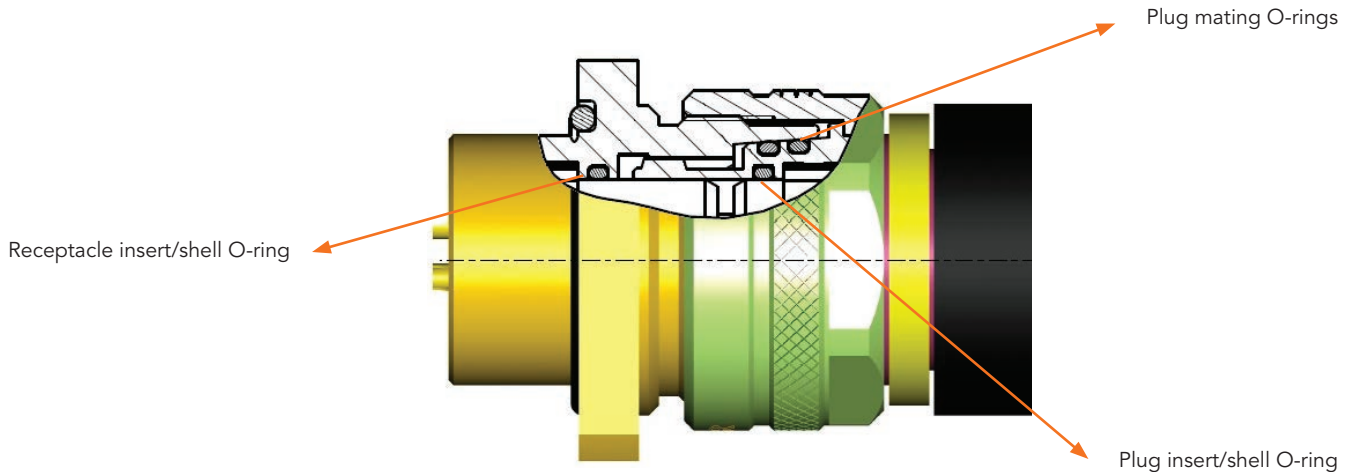

High performance sealing and mechanical retention

- ▶ **Standard watertightness: Perfect sealing on cable jacket** is achieved with the compression of a pressure gland integrated into the plug's backshell. Robust cable clamp ensures the **mechanical retention of the cable** and a removable protective boot is added on the backshell for additional sealing and cable support.

M type cable clamp set example

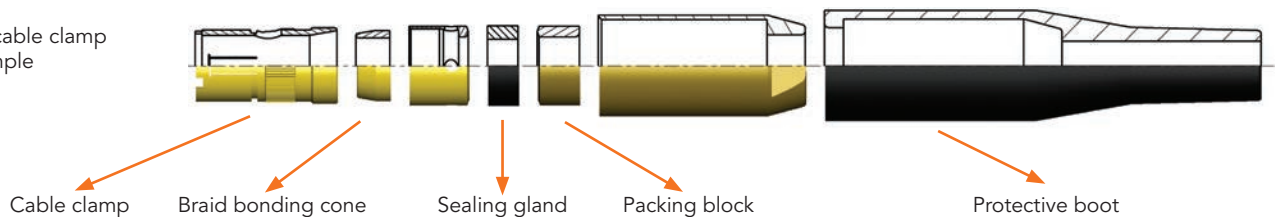

2 cable clamp sets are presented on page 25 and 26:

A type: Without 360° braid termination

M type: With 360° braid termination

- ▶ **Plugs for cable overmold (SA type): Increased pressure rating.** Shell shape enables excellent resin adhesion on PUR and Neoprene® jackets.

- ▶ **Double watertightness*:** The solution for cables with outer and inner sheaths. Compared with standard watertightness plugs, an integrated compound housing allows the sealing between the inner sheath and the shell. The sealing on the outer sheath is made with a pressure gland. It provides an extra protection in case of water ingress due to outer jacket damage.

- ▶ **Pressure Balanced Oil Filled*:** Special shell for pressure balanced oil filled harnesses.

*Please consult us

Features & Benefits

High grade materials for long term immersion

- ▶ Shells are manufactured from Nickel Aluminium Bronze which has been specifically developed for underwater applications and is proven to be highly corrosion resistant in sea water. This material has excellent electrical conductivity properties and is extremely robust and long lasting.
- ▶ Good resistance to biological fouling
- ▶ Insulators are made of PTFE or PCTFE which features near zero water absorption and excellent electrical insulating properties.
- ▶ O-rings are made from Nitrile for excellent fluid compatibility (sea water, mineral oil...) and long durability.
- ▶ Contacts are gold over nickel plated brass.
- ▶ RoHS compliant. 

Easy wiring and installation

- ▶ Scoop proof: No risk of damaging contacts during the coupling operation when using a female plug and a male receptacle.
- ▶ Removable insulators: To allow easy wiring and replacement in case of wiring mistakes or servicing.

Standard range page 15 to 38

Receptacles

- ▶ RER: Jam nut
- ▶ REC: Square flange
- ▶ RECSC: Cable connecting

Feedthrough

- ▶ TER: Jam nut feedthrough
- ▶ TEC: Square flange feedthrough

Pressure sealing caps

- ▶ BER: For receptacles, in-line receptacles and feedthroughs
- ▶ BEF: For plugs

Plugs

- ▶ FED: Plug
- ▶ FED (SA or SB): Plug for cable overmolding

In-line receptacles

- ▶ PCE: In-line receptacle
- ▶ PCE (SA or SB): In-line receptacle for external overmolding

Typical harness



▶ REC



▶ FED



▶ FED

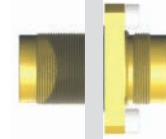

▶ TEC



▶ FED (SA)

overview

Range extension page 42 to 48

Various possibilities of range extension & shell variant from standard series

▶ The only limit is your imagination, Consult us!

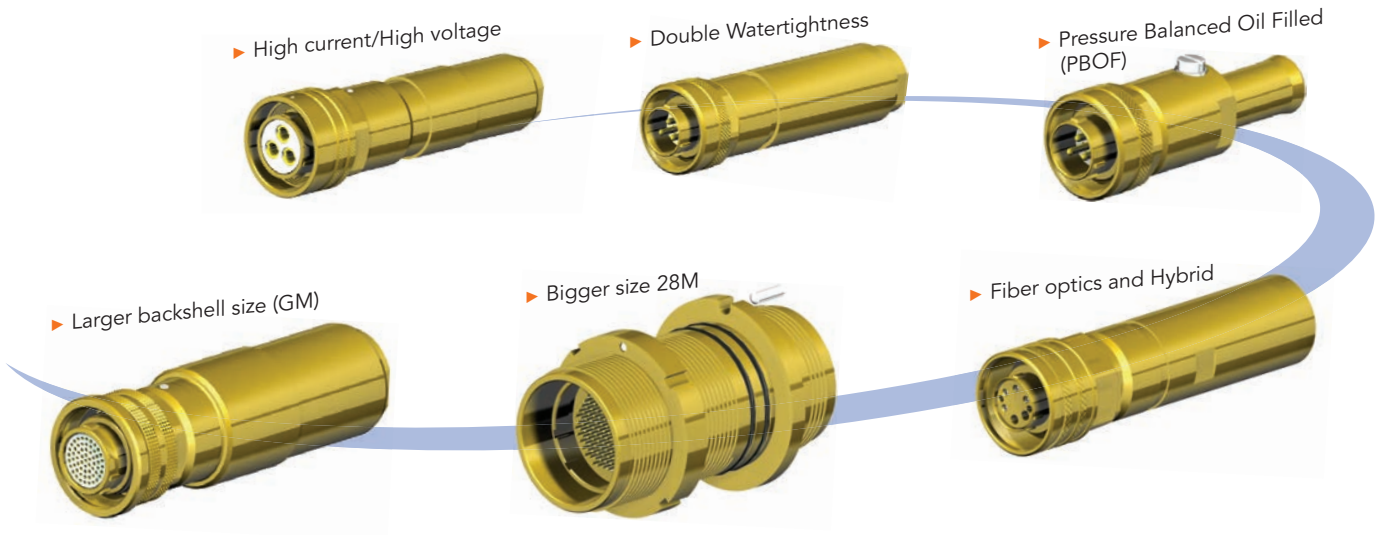

examples



Receptacles



REC



RER

Cable Receptacles



RECSC



RDECSC*

Feedthroughs



TEC



TER



PCE



PCE (SA or SB)

In-Line Receptacles



PCDE*



PCE (PBOF)*

Pressure Balanced Oil Filled

FED



FED (SA/SB)



Plugs

FDED*



FED (PBOF)*



Pressure Balanced Oil Filled

*Contact us for more information

MARINE SERIES

M Series

Standard Range

■ Product description	16
■ Technical features	17
■ Ordering information.....	19
■ Contacts	21
■ Layouts	22
■ Cable clamp accessories	25
■ Shell dimensions.....	28
■ Tools & Wiring instructions.....	38

Product description

Standard watertightness: Straight plug + Receptacle (mated)

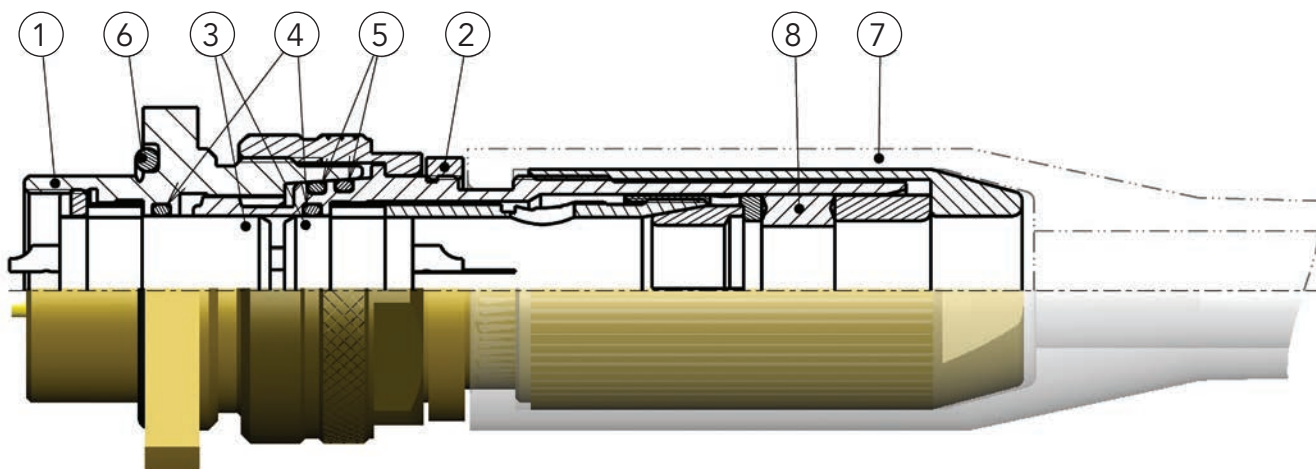

- 1. Receptacle
- 2. Plug
- 3. Insert with sealed contact
- 4. Insert/Shell O 'Ring seal

- 5. Plug/Receptacle taper seat with O'Ring seal
- 6. Panel/Receptacle O'Ring
- 7. Removable protective boot
- 8. Cable outer sheath/Plug watertightness by packing seal

Plug for cable overmolding: FED SA and SB type

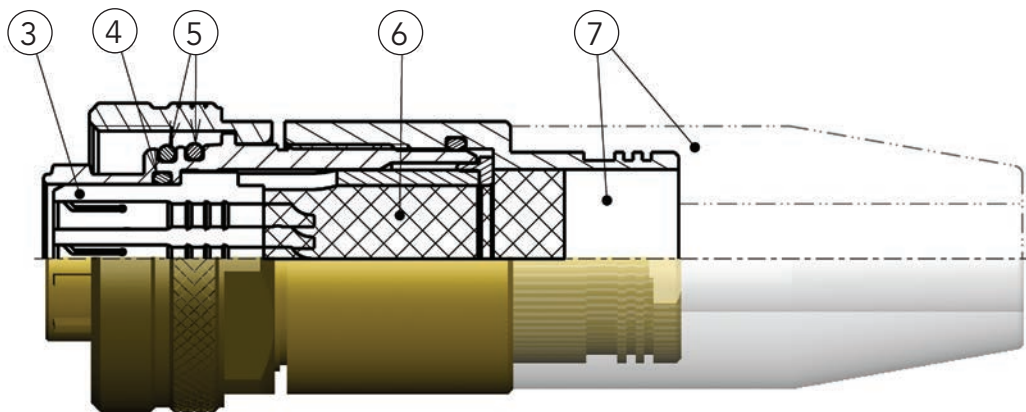

- 3. Insert with sealed contact
- 4. Insert/Shell O 'Ring seal
- 5. Plug/Receptacle taper seat with O'Ring seal

- 6. Potting housing
- 7. Outer sheath cable/Plug watertightness by customer over molding
- 8. Backshell/Plug watertightness by O'Ring seal



Description

- Marine connectors
- Screw coupling
- Sealing between plug and receptacles performed by 2 O-rings
- Standard watertightness: Sealing on cable achieved by packing washers
- Plugs for over molding (SA/SB): Sealing on cable is given by overmolding

Technical features

Mechanical

- **Shell:**
Nickel aluminium bronze
- **Insulator:**
PTFE (T)
PCTFE (K)
Other materials are available upon request (Peek, Silicone, PBTFV)
- **O-rings:**
Nitrile elastomer
- **Contacts:**
Brass
- **Contacts plating:**
Gold over nickel plated
- **Packing washers and Protection boot:**
Neoprene Elastomer
- **Endurance:**
500 mating/unmating operations
- **Shock:**
Static acceleration of 120g on each axis
- **Vibration:**
From 0,1 to 1 Hz: amplitude = 25 mm
From 1 to 5 Hz: acceleration = 0.1 g
From 5 to 22 Hz: amplitude = 1 mm
From 22 to 50 Hz: acceleration = 2 g
Duration: 1 hour on each axis

Electrical

- **Voltage rating (Vrms)**

Voltage Category	SOURIAU recommended service voltage (Vrms 50 Hz)	Dielectric Withstanding Voltage (Vrms 50Hz)
Service 0	350	1000
Service 1	600	1500
Service 2	1000	2300
Service 3	1500	3200
Service 4	5000	10000
Service 5	7000	15000

- **Insulation resistance:**
Unmated connectors : $\geq 10^4$ M Ω
Mated connectors : $\geq 5 \times 10^3$ M Ω on 500 Vcc
- **Shielding:**
Connectors mated: Resistance between the receptacle plate and the plug's cable braid : ≤ 10 m Ω

- **Current rating and contact resistance:**

Shell size	Contact size	Current rating per contact (A)	Contact resistance (m Ω)
9M 10M 14M 20M 24M	20	7	≤ 4
	16	14	≤ 3
	14	20	≤ 2.5
	12	26	≤ 2
	6	65	≤ 1
	2	115	≤ 0.6
24M	120 MC	600	≤ 0.03
10M 14M	High voltage	14	≤ 3
20M	High voltage	20	≤ 2.5
10M	Coaxial 50 Ω	20	≤ 2.5
	Coaxial 75 Ω	7	≤ 4
10M	Triaxial 50 Ω	7	≤ 4
20M	Coaxial 50 Ω		
10M	Triaxial 75 Ω	4	≤ 5
20M	Coaxial 75 Ω		
14M	Coaxial 50 Ω	40	≤ 1.5
	Triaxial 50 Ω	26	≤ 2
	Triaxial 75 Ω	14	≤ 3

Environmental

- **Operating temperature range:**

- 20°C to + 70°C

- **Watertightness**

- Mated:

Type	Standard	SA/SB
Operating pressure	≤ 100 bar	≤ 300 bar
Test	200 bar	Pressure following customer spec.

- Unmated:

Type	PTFE inserts	PCTFE inserts
Operating pressure	30 bar	60 bar ⁽¹⁾
Test pressure	40 bar	75 bar ⁽²⁾

(1) Size 9M 50 bar

(2) Size 9M 60 bar

- **Salt spray**

- 10 x (24h + 24h) alternate salt spray according to EN60068-2-11
- 500h continuous salt spray according to NFC93422

- **Fluids Resistance**

- Oil, alcohol, petrol, diesel fuel, sea water
- Various gases (natural, butane, propane, Freon)
- Various acids (acetic, boric, citric)

Ordering information

Product builder			
N°	Criteria	Choices	Pages
1	Wires type and gauge	Minimum contact size	21
2	Number of contact to connect	Contacts layout	22
3	Electrical characteristics	Layout and shell size	17
4	Cable diameters	Size checking	25
5	External pressure	Sealing type	18
6	Unmated pressure	Insert material	18
7	Cable type and construction/Braid termination	Cable clamp set	25
8	General configuration	Shell type	12 and 13

Recommendations
<p>Standard watertightness M Series connectors</p> <p>Watertightness is given by a packing-block. Watertightness performances will depend on cable quality:</p> <ul style="list-style-type: none"> . Hardness (shore A hardness > 70 is recommended) . Cylindricity and circularity . Roughness . Cable outer diameter tolerance (maximum tolerance of 1 mm on outer diameter is recommended) <p>Wiring chamber potting operation is necessary for pressure higher than 30 bar. See page 38 for potting tools.</p> <p>Overmolded plugs</p> <p>Watertightness is achieved by resin overmolding. Conductor insulation and jacket material (preferably Neoprene® or Polyurethane) of specified cable determines overmold material specification. Watertightness is determined by the adhesion of the overmold material to the cable.</p>

Standard Range

M Series connectors part numbers

Basic Series	PCE	M	14M	T	04 12	A	105
Shell type RER: Jam-nut receptacle REC: Screws mounting receptacle FED: Straight plug PCE: In-line receptacle RECSC: Screws mounting cable connecting receptacle TER: Jam-nut feedthrough TEC: Screws mounting feedthrough							
Type of contacts M: Pin contact F: Socket contacts 1: Pin/Socket (for TEC and TER feedthroughs only)							
Shell size 9M, 10M, 14M, 20M, 24M							
Insert material T: PTFE or K: PCTFE							
Contact layouts See layout tables page 22							
Cable clamp code Standard watertightness: : (nothing for RER, REC, TER & TEC) A: Without 360° braid termination M: With 360° braid termination Overmolding: (nothing for RER, REC, TER & TEC) SA: Without 360° braid termination SB: With 360° braid termination							
Maximum cable outer diameter (in tenth of mm, adjusted at upper five tenth). Example: For a 9.2mm outer diameter cable, the code is 095. Cable code for coaxial, tri-axial, high voltage (Please consult us for coding) Nothing for RER, REC, TER & TEC							

Pressure sealing cap part numbers

Basic Series	BER	C	14M
Cap type BER: For receptacles, in-line receptacles and feedthroughs BEF: For plugs			
Cable clamp set C: With cord -: Without cord (no mention)			
Shell size 9M, 10M, 14M, 20M, 24M			

Contacts - Size 2 to 20

Shell size	Contact size	Ø A (mm) Active contact OD	Ø F (mm) Contact Termination OD	Gauge AWG	Section (mm ²)	Definition
9M	20	1,02	0,9	26 to 22	0,14 to 0,38	
	16	1,59	1,2	24 to 20	0,21 to 0,60	
10M 14M 20M 24M	20	1,02	0,9	26 to 22	0,14 to 0,38	
	16	1,59	1,4	22 to 18	0,38 to 0,93	
	14	1,92	1,87	18 to 16	0,93 to 1,34	
	12	2,38	2,3	16 to 14	1,34 to 1,91	
	6	5	6,2	8 to 6	8,98 to 13,4	
	2	7	9	4 to 2	21,8 to 34,5	





Contacts - Coaxial, triaxial

Shell size	Contact size	Ø A (mm)	Ø F (mm)	Recommended cable (Please consult us)	Definition
10M	Coaxial 50Ω	1,93	2,4	KX 4 - KX 15 - NFC 93550 RG 213 U - RG 58 CU MIL C 17 F	
	Coaxial 75Ω	1,02	1,5	KX 6A - KX 8 - NF C 93550 RG 59 BU - RG 11 AU MIL C 17 F	
14M	Coaxial 50Ω	3,98	3	KX 13 - NF C 93550 MIL C 17 F - RG 217U ⁽¹⁾	
10M	Triaxial 50Ω	0,9	1,2	KX 15 - NF C 93550 MIL C 17 F - RG 58 CU ⁽¹⁾	
20-24M	Coaxial 50Ω				
20-24M	Coaxial 75Ω	0,7	0,8	KX 6A - NF C 93550 MIL C 17 F - RG 59 BU	
14M	Triaxial 50Ω	3	2,6	Depending on the cable clamp accessories, please consult us ⁽¹⁾	
	Triaxial 75Ω	1,59	1,4		



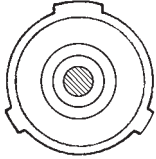
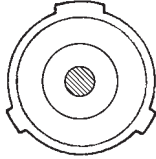
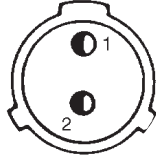

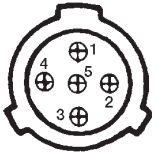
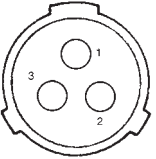

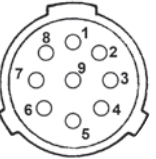

Standard Range

Contact layouts

Size 9M		Layout caption
<p>0416</p>  <p>4#16 Service 2</p>	<p>0720</p>  <p>7#20 Service 1</p>	<p>Layout ID for part numbering</p>  <p>Number of contacts #Size Voltage Service Rating</p>

Size 10M					
<p>1TX50*</p>  <p>Triax#50Ω Service 1</p>	<p>1CX50* 1CX75*</p>  <p>1Coax# 50Ω or 75Ω Service 1</p>	<p>0214</p>  <p>2#14 Service 2</p>	<p>0314</p>  <p>3#14 Service 2</p>	<p>0416</p>  <p>4#16 Service 2</p>	<p>0516</p>  <p>5#16 Service 1</p>
<p>0320</p>  <p>3#20 Service 2</p>	<p>0720</p>  <p>7#20 Service 1</p>	<p>0920</p>  <p>9#20 Service 0</p>			

*Please consult us for coax and triax layouts

Contact Type							
20	16	14	12	6	2	Coax.	Triax.
							

Contact layouts

Size 14M

1TX50*
1TX75*

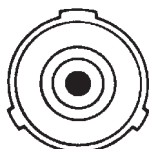

1Triax
50Ω#75
Service 2

1CX50*

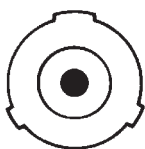

1Coax#50
Service 2

0106



1#06
Service 2

0312

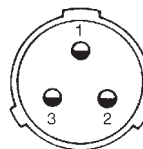

3#12
Service 2

0412

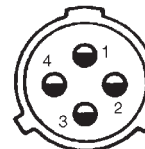

4#12
Service 2

0714



7#14
Service 2

1216

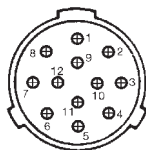

12#16
Service 2

1920

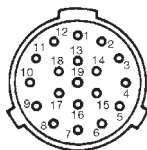

19#20
Service 1

Size 20M

4C50*
4C77*

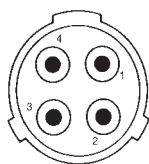

4Coax#50Ω or 75Ω
Service 1

0102

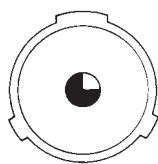

1#02
Service 2

0306



3#06
Service 2

0406

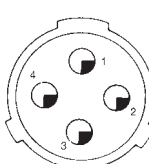

4#06
Service 2

0712

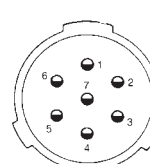

7#12
Service 2

1612

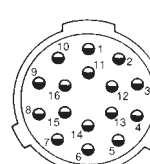

16#12
Service 2

2114

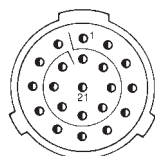

21#14
Service 1

2716

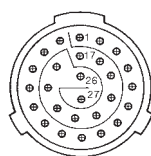

27#16
Service 1

3216

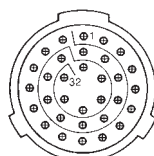

32#16
Service 1

4120

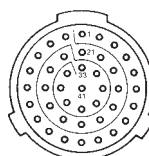

41#20
Service 1

Contact Type



*Please consult us for coax and triax layouts

Contact layouts

Size 24M

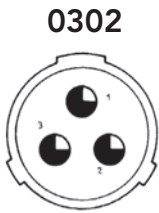

3#02
Service 2



4#02
Service 2

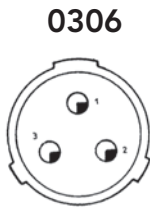

3#06
Service 2



27#12
Service 2



37#14
Service 2

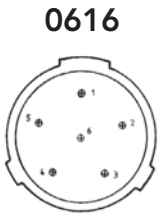

6#16
Service 4

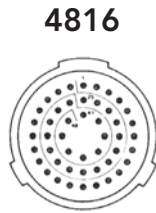

48#16
Service 1

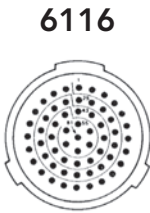

61#16
Service 1

*Please consult us for coax and triax layouts

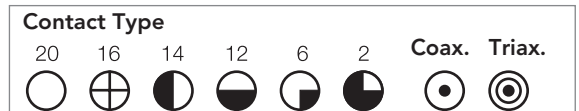

Cable clamp kits - Selection guide

Connectors	Cable Code	Description	Acceptable cable outer diameter				
			9M	10M	14M	20M	24M
Single Watertightness	A	Standard cable clamp without 360° shield termination	4-6.5	5-11	8-16	14-26	20-31
	M	Tapper cable clamp with 360° shield termination	4-6.5	5-10.5	9-16	12-24	18-32
External overmolding	SA	Overmolding backshell without 360° shield termination	< 6.5	< 10.5	< 16.5	< 24.5	< 32
	SB	Overmolding backshell with 360° shield termination	< 6	< 9	< 15	< 17.5	< 26.5

For coaxial, triaxial and high voltage contact layouts, please send us your cable datasheet to define the right cable clamp code

Standard watertightness - Cable clamp kits

BA	Insulating ring	JPE	Rubber washer	EEN	Spacer nut	DOS	Outer sleeve
CPI	Collet clamp	MDP	Protective boot	ESC	Cabling spacer	RGA	Packing washer
CSC	Shielding tapper	PSC	Cable collet	RGR	Packing block	SCA	Half collar (+ screws)

Cable clamp code	Grounding	Size	
A	No	9M	
		10M 14M 20M	
		24M	
M	Yes	9M	
		10M	
		14M	
		20M	
		24M	

Shell dimensions

RER - Jam-nut receptacle, watertight mounting

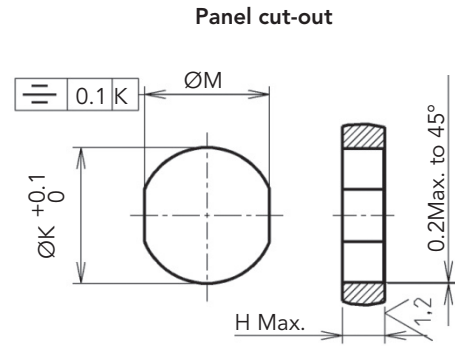
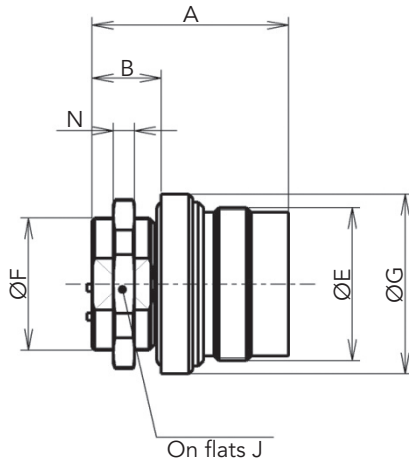

Shell size	9M	10M	14M	20M	24M
A	22	37	37	49,5	58
B	7	14	13	17	20
Ø E (ISO)	M17 x 1	M21 x 1	M29 x 1	M41 x 1	M56 x 1.5
Ø F (ISO)	M13 x 0.7	M18 x 0.75	M25 x 0.75	M36 x 1	M46 x 1.5
Ø G	20	25	34	46	64
H Max.	4	10	9	12	14
On flats J	15	22	30	41	56
Ø K	13.2	18.2	25.2	36.2	46.2
M	12.2	16.2	23.2	33.2	42.2
N	3	4	4	5	6
Average mass (g)*	Consult us	63	110	282	Consult us

*Average mass estimated by CAD

Note: All dimensions are in millimeters (mm)

Shell dimensions

REC - Square flange receptacle, watertight mounting

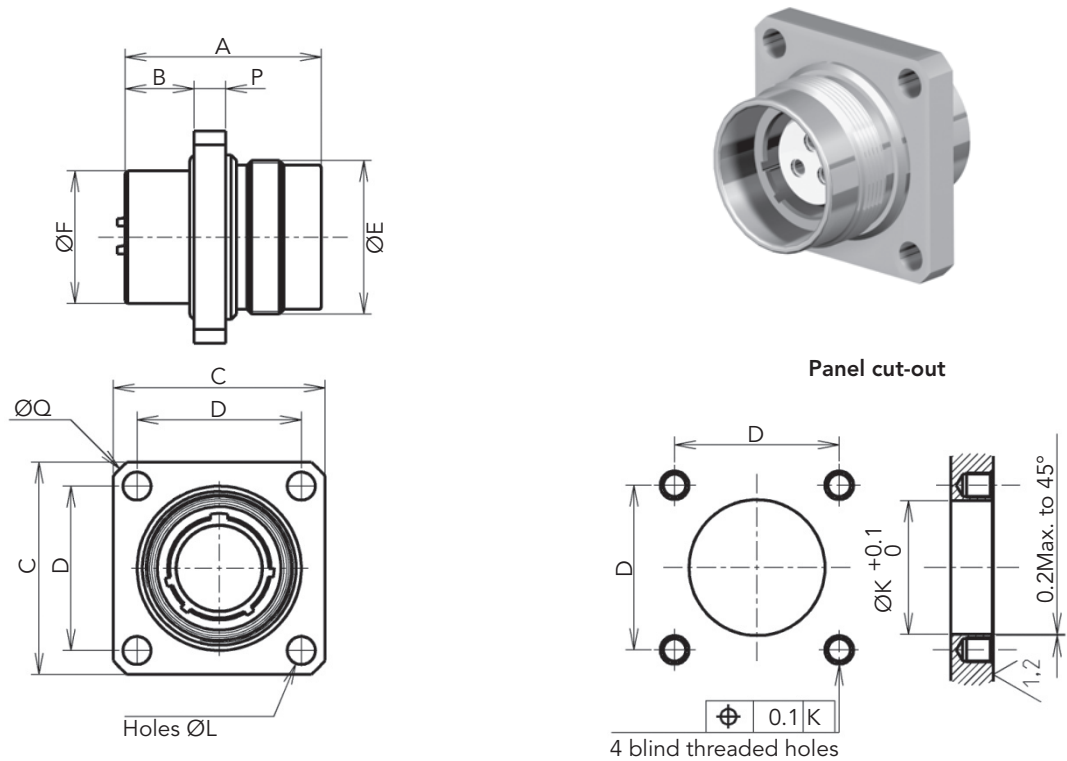

Shell size	9M	10M	14M	20M	24M
A	22	37	37	49.5	58
B	6.3	14	13	17	20
C	29	32	40	52	76
D	20	24	31	42	60
Ø E (ISO)	M17 x 1	M21 x 1	M29 x 1	M41 x 1	M56 x 1.5
Ø F	13	18	25	36	46
Ø K	13.2	18.2	25.2	36.2	46.2
Ø L	4.5	4.3	5.3	6.3	8.5
P	4	5	6	8	9
Ø Q Max.	40.5	42.5	53.5	69.5	100.5
R (ISO)	M4	M4	M5	M6	M8
Average mass (g)*	Consult us	78	133	337	739

*Average mass estimated by CAD

Note: All dimensions are in millimeters (mm)

Shell dimensions

FED - Straight plug

Shell size: 9M - 10M - 14M - 20M

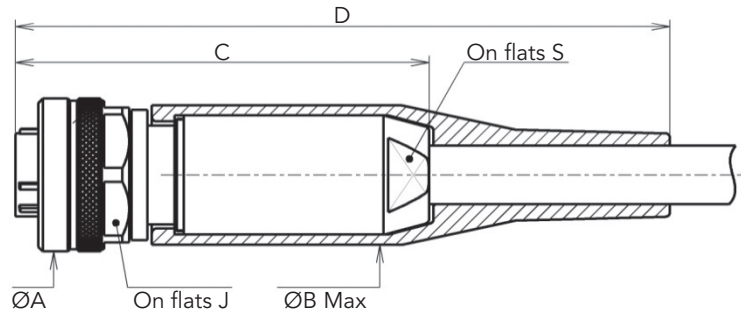

Shell size: 24M

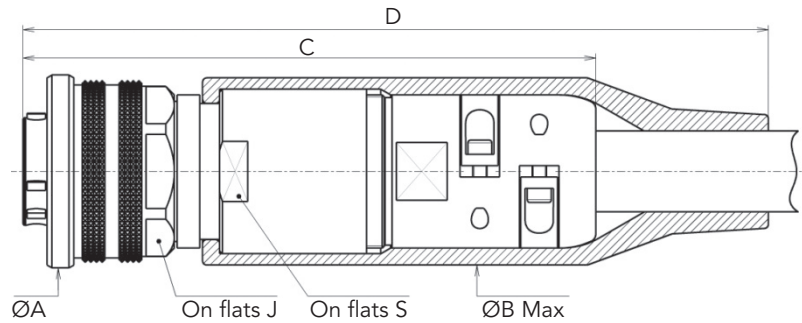

Shell size	9M	10M	14M	20M	24M
Ø A	20	25	34	46.5	68
Ø B Max.	19	23	32	45	66
C	53	73	92	115	205
D	79	110	144	186	315
On flats J	17.46 (11/16")	22	30	42	54
On flats S	12	16	20	30	54
Average mass (g)*	Consult us	141	334	822	3170

*Average mass estimated by CAD

Note: All dimensions are in millimeters (mm)

Shell dimensions

PCE - In-line receptacle

Shell size: 9M - 10M - 14M - 20M

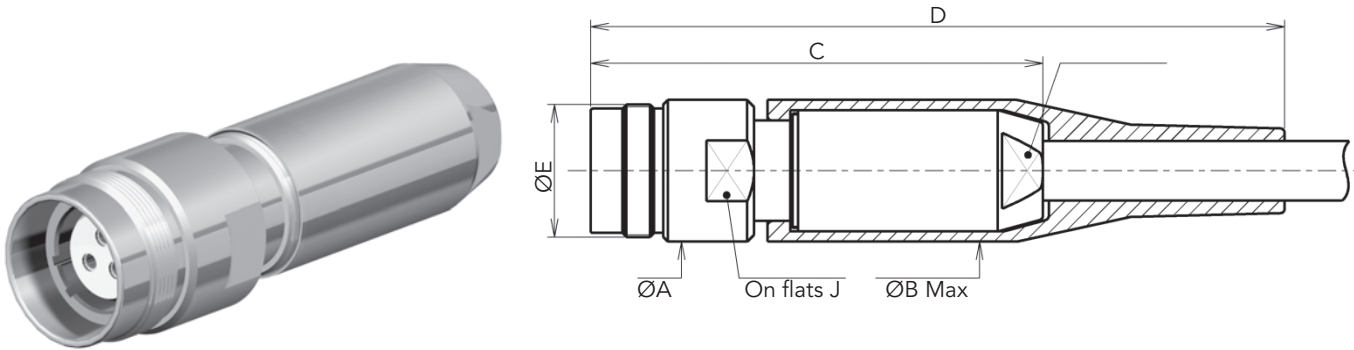

Shell size: 24M

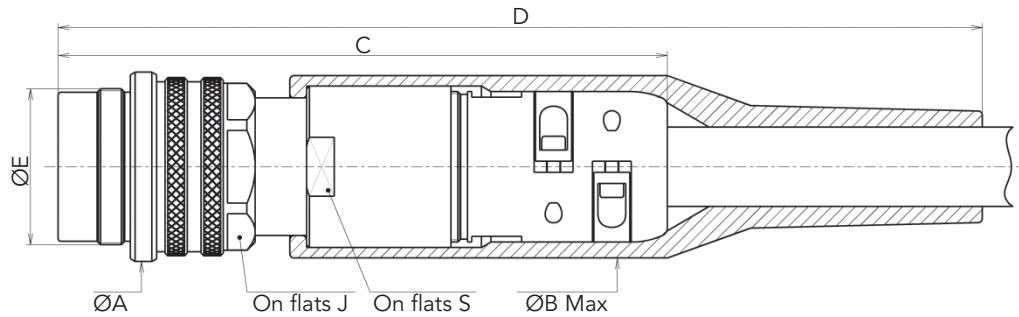

Shell size	9M	10M	14M	20M	24M
Ø A	19	23	31	43	68
Ø B Max.	20	23	32	45	66
C	57	82	100	127	220
D	84	120	153	198	335
Ø E (ISO)	M17 x 1	M21 x 1	M29 x 1	M41 x 1	M56 x 1.5
On flats J	17	20	28	38	54
On flats S	12	16	20	30	54
Average mass (g)*	Consult us	160	359	888	3491

*Average mass estimated by CAD

Note: All dimensions are in millimeters (mm)

Shell dimensions

RECSC - Square flange cable connecting receptacle

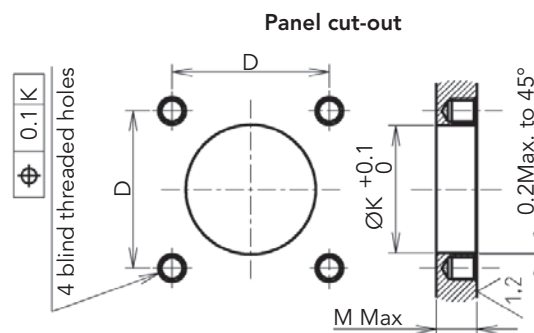
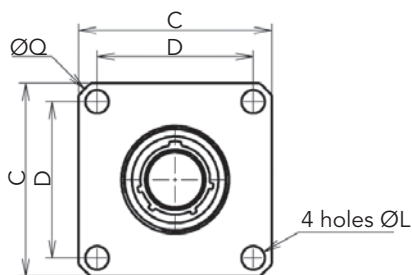
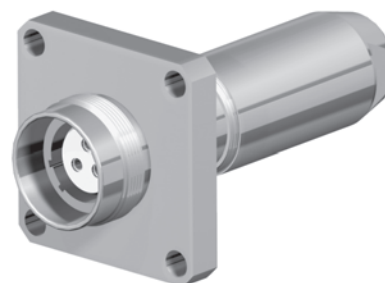
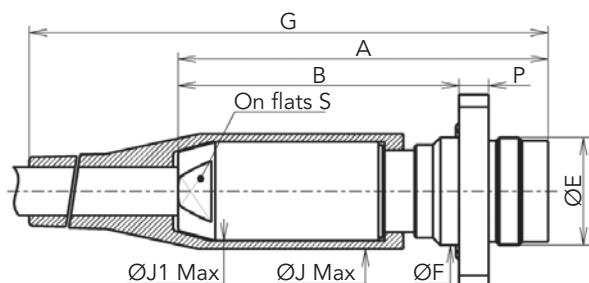

Shell size	9M	10M	14M	20M	24M
A	57	82	100	127	220
B	42	58	76	97	170
C	32	40	52	76	96
D	24	31	42	60	70
Ø E	M17 x 1	M21 x 1	M29 x 1	M41 x 1	M56 x 1.5
Ø F	18	22	29	41	69
G	84	120	153	198	335
H Max.	10	12	12	20	/
Ø J Max.	20	23	32	45	66
Ø J1 Max.	17	20	27	39	54
Ø K	18.2	22.2	29.2	41.2	69.2
Ø L	4.3	5.3	6.3	8.5	12.5
P	4	8	8	9	12
Ø Q Max.	42.5	53.5	69.5	100.5	119.5
R	M4	M5	M6	M8	M12
On flats J	12	16	20	30	54
Average mass (g)*	Consult us	224	462	Consult us	3074

*Average mass estimated by CAD

Note: All dimensions are in millimeters (mm)

Shell dimensions

FED Plug and PCE in-line receptacles for cable overmolding - SA and SB versions



FED



PCE

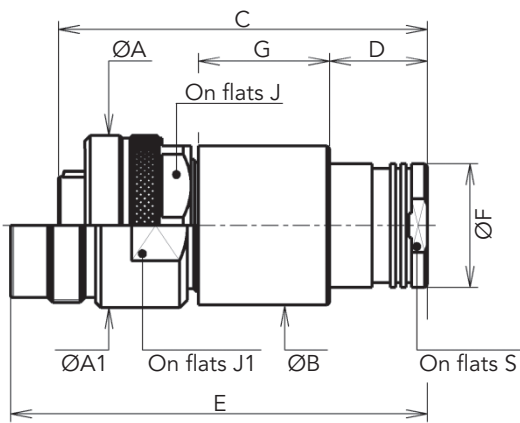

Shell size: 9M - 10M - 14M - 20M

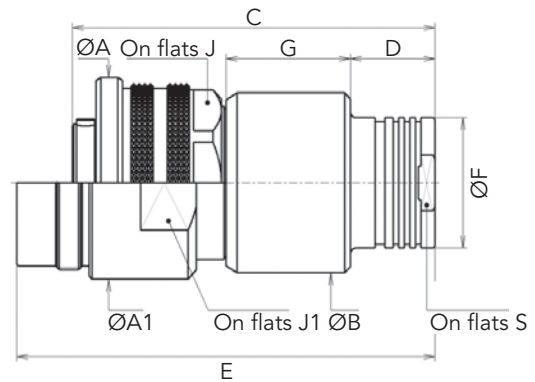

Shell size: 24M

Shell size	9M	10M	14M	20M	24M
Ø A / Ø A1	20/19	25/23	34/31	46/43	68/68
Ø B	17.5	22	30	42	58
C	45	63	73	88	132
D	15.5	15.5	18.5	20.5	30.5
E	49	73	83	100	151
Ø F	14	17.5	23.5	32	42
G	11	20	25	29.5	45
On flats J On flats J1	17.46/17	22/20	30/28	42/38	54/54
S sur plats/On flats S	12	15	21	29	38
Average mass (g)*	Consult us	Consult us	195/220	454/Consult us	1335/1569

*Average mass estimated by CAD

Note: All dimensions are in millimeters (mm)

Shell dimensions

TER - Jam-nut feedthrough

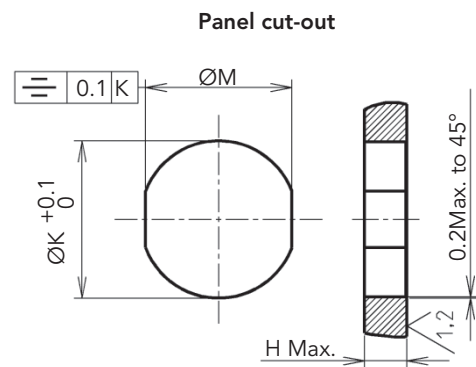
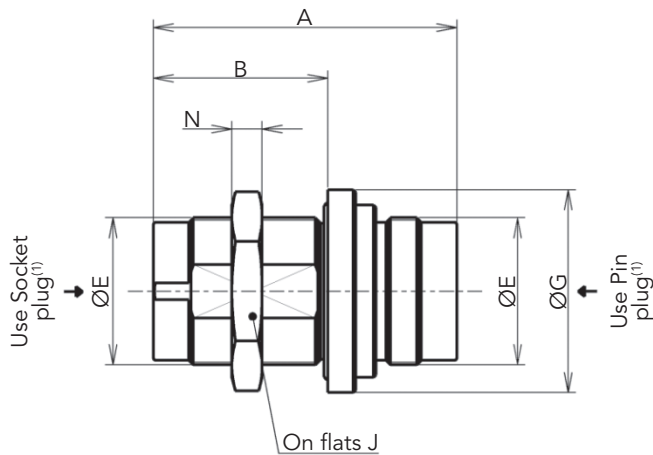
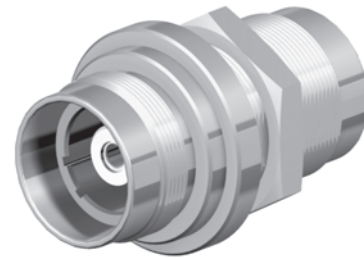

Shell size	9M	10M	14M	20M	24M
A	50	60	60	82	98
B	34.5	35.5	34.5	47.5	57
Ø E (ISO)	M17 x 1	M21 x 1	M29 x 1	M41 x 1	M56 x 1.5
Ø G	23	28	40	52	70
H Max.	19	16	13	22	23
On flats J	20	24	34	46	63
Ø K	17.2	21.2	29.2	41.2	56.2
M	14.2	19.2	27.2	39.2	50.2
N	4	4	6	5	8
Average mass (g)*	Consult us	113	222	Consult us	Consult us

*Average mass estimated by CAD

Note: All dimensions are in millimeters (mm)

Shell dimensions

TEC - Square flange feedthrough

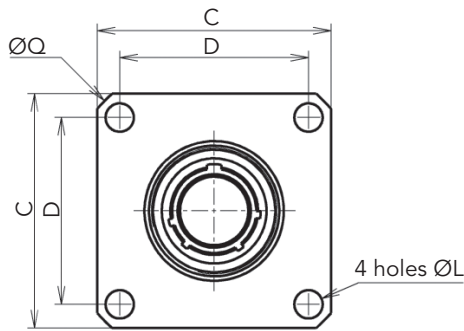
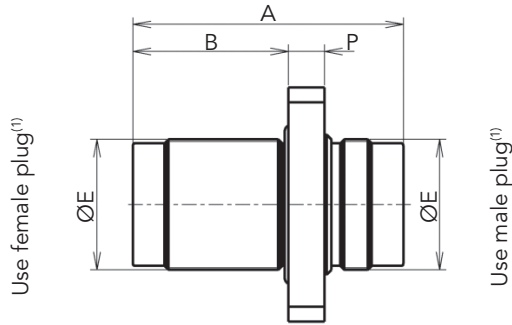

Panel cut-out

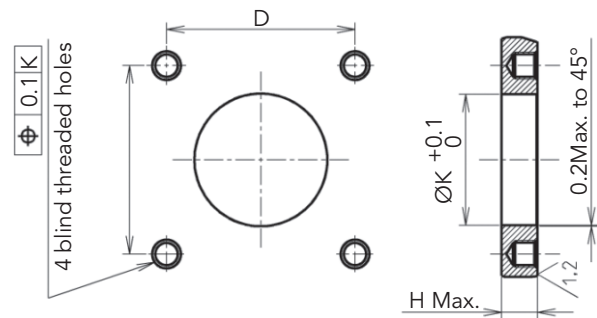

Shell size	9M	10M	14M	20M	24M
A	50	60	60	82	98
B	34.5	35.5	34.5	47.5	57
C	32	40	52	76	76
D	24	31	42	60	60
Ø E (ISO)	M17 x 1	M21 x 1	M29 x 1	M41 x 1	M56 x 1.5
H Max.	23	20	19	27	31
K	17.2	21.2	29.2	41.2	56.2
Ø L	4.3	5.3	6.3	8.5	8.5
P	4	6	8	9	12
Ø Q Max.	42.5	53.5	69.5	100.5	100.5
R (ISO)	M4	M5	M6	M8	M8
Average mass (g)*	Consult us	Consult us	299	Consult us	Consult us

*Average mass estimated by CAD

Note: All dimensions are in millimeters (mm)

Shell dimensions

Pressure sealing caps

BEF - Cap for plug

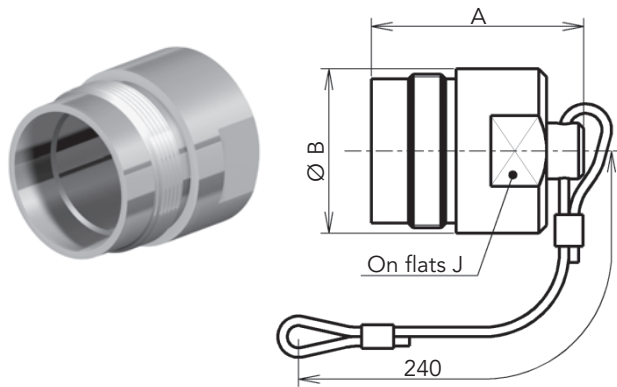

BER - Cap for receptacle

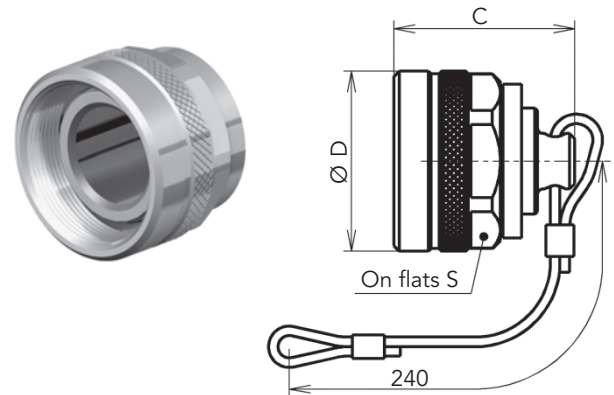

Shell size	9M	10M	14M	20M	24M
A	30	39	40	52.5	71
Ø B	19	23	31	43	64
C	27.5	34	34	47.5	69
Ø D	20	25	34	46.5	68
On flats J	17	20	28	38	54
On flats S	17,46	22	30	42	54

Mated/Unmated connectors

R = Mated shells overlap

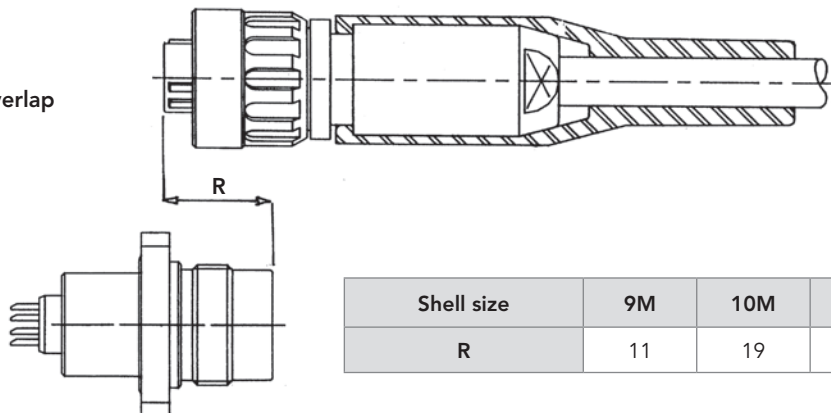

Shell size	9M	10M	14M	20M	24M
R	11	19	19	25	32

Note: All dimensions are in millimeters (mm)

Insert + Contacts sub assemblies part numbers

Insert + Contacts Sub Assembly	BIS	14M	T	04 12	M
Shell type: 9M, 10M, 14M, 20M, 24M					
Insert material T: PTFE K: PCTFE for standard layouts					
Contact layouts See layout tables					
Type of contacts M: Pin contacts F: Socket contacts					

Cable clamp kits part numbers

Kit type: See page 26 RAE: Full cable clamp kit RAER: Cable clamp kit sub assembly	RAE	14M	A	100
Shell size: 9M, 10M, 14M, 20M, 24M				
Cable clamp Code Standard watertightness: (nothing for RER, REC, TER & TEC) A: Without 360° braid termination M: With 360° braid termination				
Maximum cable outer diameter (in tenth of mm, adjusted at upper five tenth). Example: For a 9.2mm outer diameter cable, the code is 095. Cable code for coaxial, tri-axial, high voltage & double watertightness (consult us for coding)				

O-rings part numbers

O-ring Type	9M	10M	14M	20M	24M
❶ Panel O-ring (for REC-RER)	09-01	10-01	14-01	20-01	24-01
❷ Insulator/Shell O-ring	09-02	10-02	14-02	20-02	24-02
❸ Taper seat O-rings	09-03	10-03	14-03	20-03	24-03
❹ Panel O-rings (for TEC-TER)	09-04	10-04	14-04	20-04	24-04
❺ Panel O-ring (for RECSC)	10-01	20-02	14-05	20-04	24-05

REC-RER Receptacles

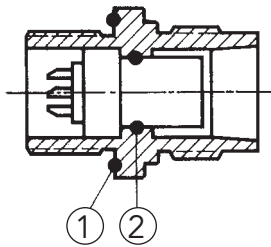

FED Plug

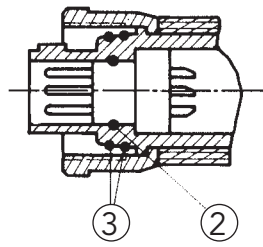

PCE Cable connecting plug

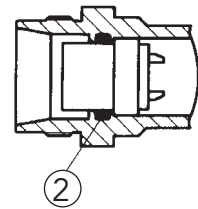

TEC-TER Bulkhead

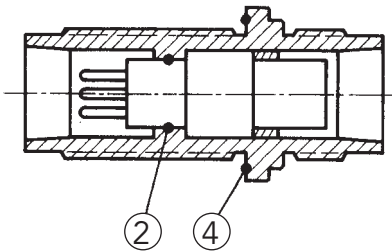

BER Cap

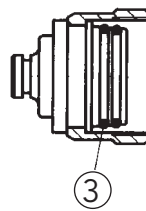

RECSC Square flange in-line receptacle

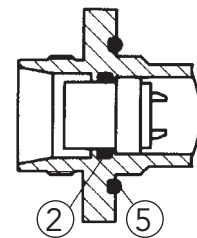

Tools

Plug wiring tools

These tools are used to maintain correctly plugs during the final operation of wiring: tightening the tightening sleeve

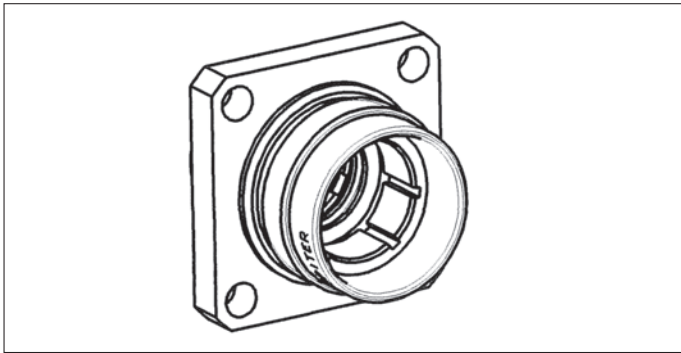

Plug Size	Tool P/N
9M	MA1W6010B5
10M	MA2W6010B5
14M	MA3W6010B5
20M	MA4W6010B5
24M	MA5W6010B5

Contact assembling tool

The removable contacts are held in the insert by a special nut, which can be screwed or unscrewed, using the tools below

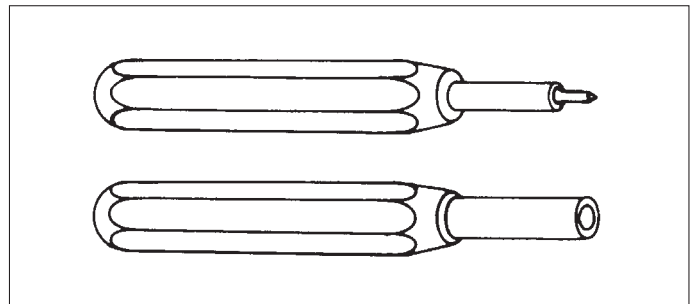

Contact type	Tool P/N
Male size 6	OUT.BMV.20M.16MC
Female size 6	OUT.BFV.20M.16MC
Male size 2	OUT.BMV.20M.35MC
Female size 2	OUT.BFV.20M.35MC
10M triaxial 50 Ω - 75 Ω/24/20M coaxial 50 Ω - 75 Ω Male and female	OUT.MC.04

Plastic jaw plier

This tool is used for holding the cable clamp while tightening the sleeve

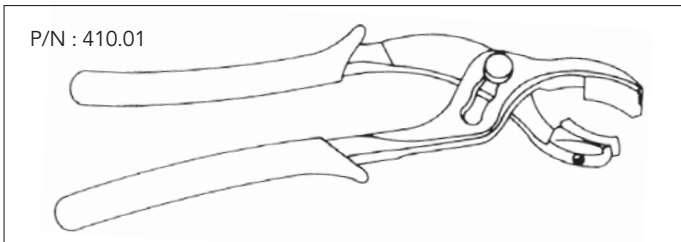

Potting tool

Used to fill with resin cabling spacers

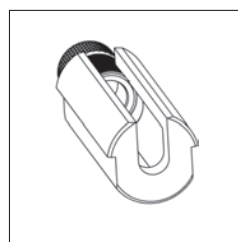

Size	Tool P/N
10M	OUT330 10M
14M	OUT330 14M
20M	OUT330 20M
24M	MA5W4001A9

End wrenches

Used to tighten coupling ring of size 20M or 24M with a torque wrench

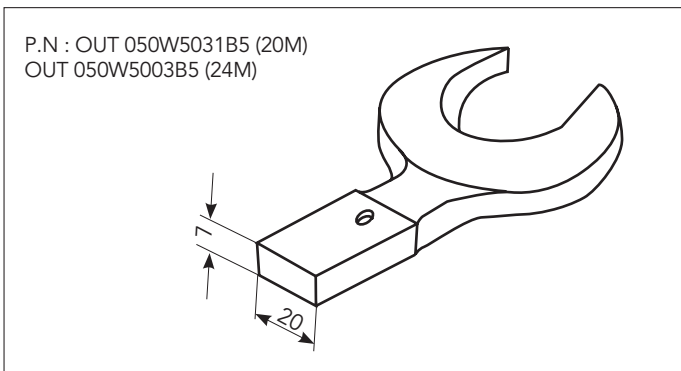

The wiring and installation instruction for M Series connectors can be provided upon request.

MARINE SERIES

M Series

Range Extension

■ Double watertightness connectors.....	41
■ Oil filled connectors	42
■ Specific shell types	43
■ Optical M connectors.....	43
■ Size 28M and bigger shell sizes.....	44
■ High current/High voltage.....	44

Product range extension

Double Watertightness

The solution for the highest safety with double armored cables.

A double watertightness solution:

- . Sealing between the cable outer sheath and the backshell thanks to a sealing gland.
- . Sealing between the cable inner sheath and the backshell thanks to potting.

Provides an extra sealing protection in case of water ingress due to outer jacket damage

For more information, please consult us



PBOF: Oil Filled Plug and In-line Receptacle

The solution for very deep immersion with oil filled cables.

High pressure withstand:

- . Up to 1000 bars
- . Dielectric oil filling
- . Balances out the pressure difference
- . Water cannot enter the plug shell when the cable is damaged

For more information, please consult us



Product range extension

GM Range Larger Backshell Size

Plugs and in-line receptacle with magnified backshells for larger than standard cable mounting.

Size	10GM	14GM	20GM	24GM
Maxi cable OD(mm)	14	19	28,5	40

For more information, please consult us



Optical M Connectors

Watertight up to 100bar for optical or hybrid connectors. Based on three existing shells, 14MO, 20MO and 24MO.

For more information, please consult us



Product range extension

Size 28

The biggest M Series connector size.

Special layouts:

- . Up to 126 contacts
- . Coax and hybrid layouts
- . High power. Up to 3 x 290A

For more information, please consult us



High Current and High Voltage

High current and high voltage layouts can be available upon request.

High voltage

- . Up to 15 000VRMS (Dielectric Withstanding Voltage at 50 Hz)

High current

- . Up to 600A with 120 mm² contacts

For more information, please consult us



Notes

A large grid area for taking notes, consisting of 20 columns and 30 rows of small squares.

MARINE SERIES

M Series

Other Series

■ TP Series.....	48
■ U Series	48
■ 8810 Series.....	49

Other Series

TP Series

Economic connectors similar to M Series with nickel plated brass shells and PA6/6 molded inserts.
See specific catalog available online.

Sealed:

- . Down to 300 meters depth

Large range:

- . 4 shell sizes: 8TP, 10TP, 14TP and 20TP
- . Receptacles, cable receptacles, plugs and feedthroughs.
- . Signal, power, high voltage, coax and triax contacts

Economic underwater solution

RoHS compliant 



U Series

Connectors similar to M Series with 316L stainless steel shells and FPM seals.
See specific catalog.

High pressure withstand:

- . Down to 300 meters depth

Robust:

- . High corrosion resistant stainless steel shell (AISI 316L)
- . Robust screw coupling mechanism
- . High temperature resistance (up to 170°C with PTFE insulators)
- . Nylatron, Teflon or Tefzel insulators
- . Radiation withstanding (up to 100 MRads)

RoHS compliant 



Other Series

8810 Series

Wet/underwater mateable connectors for deep immersion. See specific catalog available online.

High pressure withstand:

- . Down to 3000 meters depth

Robust:

- . Marine bronze shells
- . Robust screw coupling mechanism

RoHS compliant 



Notes

A large grid area for taking notes, consisting of 20 columns and 30 rows of small squares.

Reliable People, Reliable Solutions



Your local contact



Our contribution to environmental protection:
This catalog is printed on PEFC certified paper
Advancement of sustainable wood cultivation. www.pefc.org

www.souriau.com
contactmilaero@souriau.com



SOURIAU